

DESCRIPTION

An increasing number of applications require the use of high-temperature crystals. For these applications, Statek offers the CX1HT-06, CX2HT-06 and CX2HT-07 leaded crystals. These crystals are designed to operate at temperatures up to and including 175°C. The frequency range offered is 8 MHz to 250 MHz for CX1HT-06 and 9.6 MHz to 250 MHz for CX2HT-06 and CX2HT-07 crystals. The expected life at 175°C is in excess of 1,000 hours.

FEATURES

- High temperature operation up to 175°C
- High shock resistance
- Hermetically sealed ceramic package
- Through-hole leaded package
- Reduces mechanical and thermal mounting stresses

APPLICATIONS

Industrial

- Downhole instrumentation
- Rotary shaft sensors
- Underground boring tools

PACKAGE DIMENSIONS - CX2HT

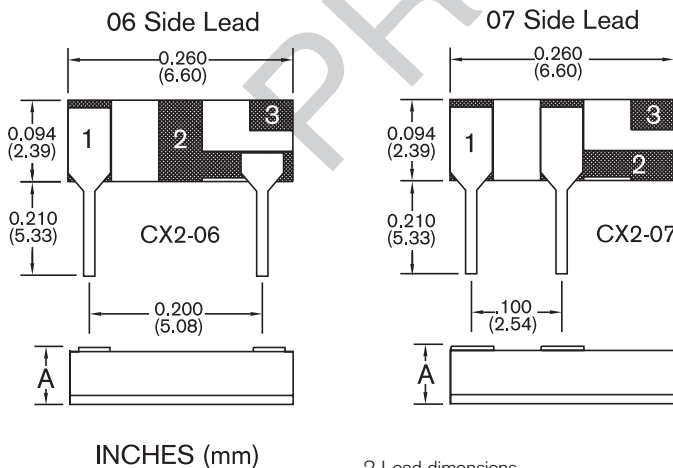

2. Lead dimensions
Width: 0.013" (0.33mm) Typical
Thickness: 0.0055" (0.14mm) Typical
3. A = Glass Lid 0.080 (2.03) max.
Ceramic Lid 0.095 (2.41) max.

Notes:
1. Terminal 1 is electrically connected internally to terminal 3.

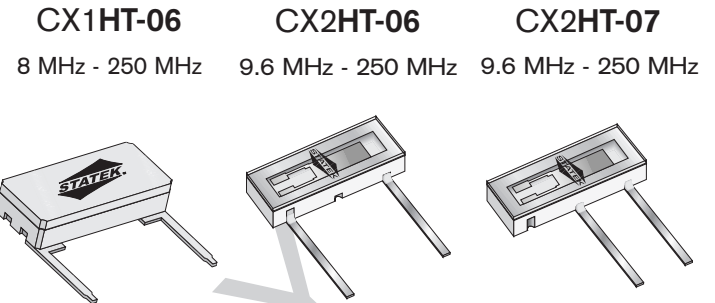

PACKAGE DIMENSIONS - CX1HT-06

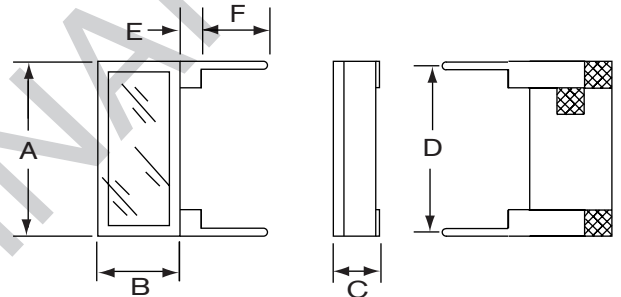

CX1HT DIM	TYPICAL		MAXIMUM	
	INCHES	mm	INCHES	mm
A	0.315	8.00	0.330	8.38
B	0.140	3.56	0.155	3.94
C			0.080	2.03 (glass)
C			0.095	2.41 (ceramic)
D	0.300	7.62	0.310	7.87
E	0.020	0.51	0.040	1.02
F	0.150	3.81	0.160	4.06

Leads: Thickness 0.010" x 0.018" Width (0.25 x 0.46 mm) typical.

EQUIVALENT CIRCUIT

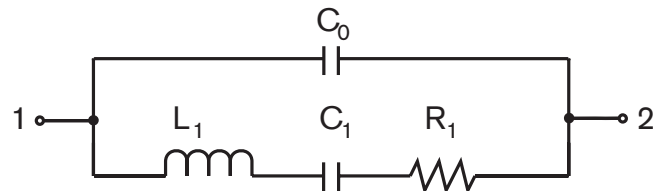

R₁ Motional Resistance L₁ Motional Inductance
C₁ Motional Capacitance C₀ Shunt Capacitance

SPECIFICATIONS

Specifications are typical at 25°C unless otherwise noted.
Specifications are subject to change without notice.

Frequency Range	See Specifications Table below
Calibration Tolerance ¹	± 100 ppm, or tighter, as required
Operating Temperature Range ²	+25°C up to +175°C
Frequency-Temperature Stability ³	± 125 ppm for +25°C to +150°C ± 150 ppm for +25°C to +175°C
Total Tolerance ⁴	± 200 ppm for +25°C to +175°C
Aging, first year	5 ppm at 25°C
Shock, survival ⁵	1,000 g, 1 ms, 1/2 sine
Vibration, survival ⁵	20 g RMS, 10-2,000 Hz

1. Tighter frequency calibration available. Contact factory.
2. Other temperature ranges available.
3. Does not include calibration tolerance. The characteristics of the frequency stability over temperature follow that of the thickness-shear mode.
4. Includes calibration tolerance.
5. Higher shock and vibration available.

ABSOLUTE MAXIMUM RATINGS

Storage Temperature	-55°C to 125°C
Maximum Process Temperature	200°C for 10 sec.

PACKAGING OPTIONS

- Tray Pack

PACKAGE HANDLING

Take proper soldering consideration as the melting temperature of the lead-attach solder is 217°C

SPECIFICATIONS TABLE¹ (Specifications shown are typical unless otherwise noted.)

	Frequency Range	Motional Resistance R1 @ 25°C	Motional Capacitance C1 @ 25°C	Shunt Capacitance C0 @ 25°C	Quality Factor Q @ 25°C	Load Capacitance CL Load	Drive Level
CX1HT	8 MHz to 250 MHz	30 Ω @ 10 MHz 25 Ω @ 32 MHz	5.5 fF @ 10 MHz 6.2 fF @ 32 MHz	2.2 pF @ 10 MHz 2.3 pF @ 32 MHz	100 K @ 10 MHz 30 K @ 32 MHz	20 pF for f ≤ 50 MHz 10 pF for f > 50 MHz	500 μW MAX. for f ≤ 50 MHz 200 μW MAX. for f > 50 MHz
	CX2HT	9.6 MHz to 250 MHz	60 Ω @ 10 MHz 30 Ω @ 32 MHz	2.8 fF @ 10 MHz 6.2 fF @ 32 MHz	1.4 pF @ 10 MHz 2.3 pF @ 32 MHz	95 K @ 10 MHz 30 K @ 32 MHz	20 pF for f ≤ 50 MHz 10 pF for f > 50 MHz

1. For more detailed specifications on high frequency crystals, refer to standard high frequency crystal datasheets (CX1SM, CX2SM)

HOW TO ORDER CX1VHT-06, CX2VHT-06 and CX2VHT-07 CRYSTALS

