



HIGH TEMPERATURE OSCILLATORS

32.768 kHz

High Stability/Fast Start-up/High Shock

DESCRIPTION

For **high temperature**, high stability and fast start-up applications, Statek offers the AT crystal-based 32.768 kHz CXOMHT and CXOXHT oscillators. These oscillators are designed to operate at temperatures up to 200°C. A high-shock version is also offered that features 10,000 g shock survivability. Other features include fast start-up time (0.8 ms typical) and low current operation (500 μ A at 25°C.)

FEATURES

- High temperature operation up to 200°C
- Overall 5 times improvement in total frequency stability when compared to a typical tuning fork design
- A High-Shock version that features 10,000 g shock survivability is also offered
- Excellent stability over temperature
- Fast start-up
- CMOS and TTL compatible
- Optional output enable/disable
- Low current
- Hermetically sealed ceramic package
- Full military testing available

APPLICATIONS

Industrial

- Downhole instrumentation
- Rotary shaft sensors
- Underground boring tools

SUGGESTED LAND PATTERN

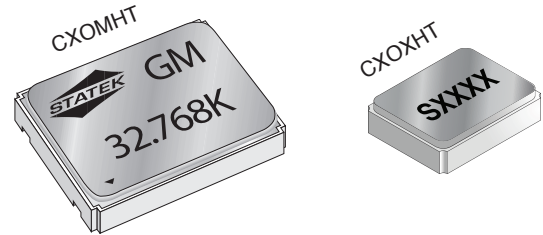
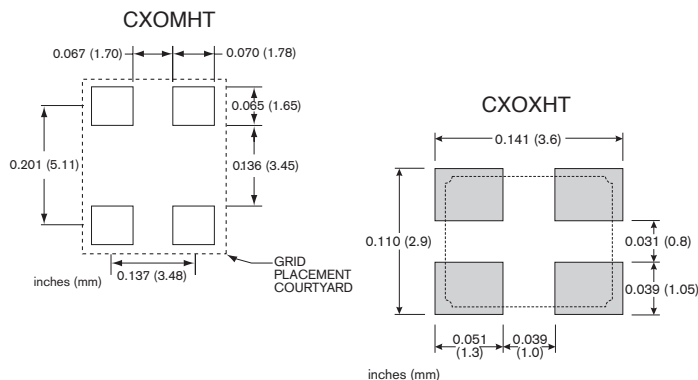

PACKAGE DIMENSIONS

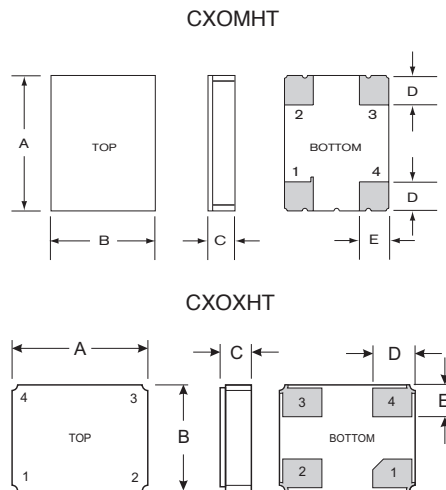

DIM	CXOXHT		CXOMHT	
	MAXIMUM		MAXIMUM	
	inches	mm	inches	mm
A	0.136	3.40	0.263	6.68
B	0.107	2.70	0.204	5.18
C (SM1)	0.043	1.09	0.055	1.40
C (SM3/SM5)	0.048	1.21	0.063	1.60
D	0.041	1.10	0.065	1.65
E	0.031	0.85	0.070	1.78

PIN CONNECTIONS

1. Enable/Disable (E) or No Connection (N)
2. Ground
3. Output
4. V_{DD}

10201 Rev A



SPECIFICATIONS

Specifications are typical at 25°C unless otherwise noted. Specifications are subject to change without notice. Tighter specifications available. Please contact factory.

Supply Voltage	3.3 V ± 10%
Calibration Tolerance	± 100 ppm, or tighter as required
Frequency Stability over Temperature	± 100 ppm for 25°C to 150°C ± 150 ppm for 25°C to 175°C ± 175 ppm for 25°C to 200°C
Total Tolerance ¹	± 200 ppm for 25°C to 200°C
Supply Current (Typical)	500 µA
Output Load (CMOS)	15 pF
Start-up Time	0.8 ms typical
Rise/Fall Time	85 ns/ 45 ns
Duty Cycle	40% MIN, 60% MAX
Aging, first year	10 ppm MAX at 25°C
Aging, 1,000 Hrs	100 ppm MAX at 200°C
Shock, survival	CXOXHT Std: 5,000 g, 0.3 ms, 1/2 sine CXOMHT Std: 3,000 g, 0.3 ms, 1/2 sine
CXOM & CXOX	HG: 10,000 g, 0.3 ms, 1/2 sine
Vibration, survival ²	20 g, 10-2,000 Hz swept sine
Operating Temp Range	-55°C up to 200°C

1. Includes calibration tolerance. Other tolerances available.

2. Per MIL-STD-202G, Method 204D, Condition D. Random vibration testing available.

Note: All parameters are measured at ambient temperature with a 10 MΩ, 15 pF load.

ABSOLUTE MAXIMUM RATINGS

Supply Voltage V_{DD}	-0.3 V to 5.0 V
Storage Temperature	-55°C to 125°C
Maximum Process Temperature	260°C, 20 seconds

ENABLE/DISABLE OPTIONS (E/N)

For the 32.768 kHz CXOXHT and CXOMHT, Statek offers two enable/disable options: E and N. The E-version has a Tri-State output and stops oscillating internally when the output is put into the high Z state. The N-version does not have PIN 1 connected internally and so has no enable/disable capability. The following table describes the Enable/Disable option E.

ENABLE/DISABLE OPTION E FUNCTION TABLE

	Enable (Pin 1 High*)	Disable (Pin 1 Low)
Output	Frequency output	High Z State
Oscillator	Oscillates	Stops
Current	500 µA at 25°C	3.2 µA at 25°C

* When PIN 1 is allowed to float, it is held by an internal pull-up resistor.

PACKAGING OPTIONS

CXOXHT, CXOMHT - Tray Pack

- 16 mm tape, 7" or 13" reels

Per EIA 481 (see Tape and Reel data sheet # 10109)

HOW TO ORDER 32.768 kHz CXOMHT and CXOXHT OSCILLATORS

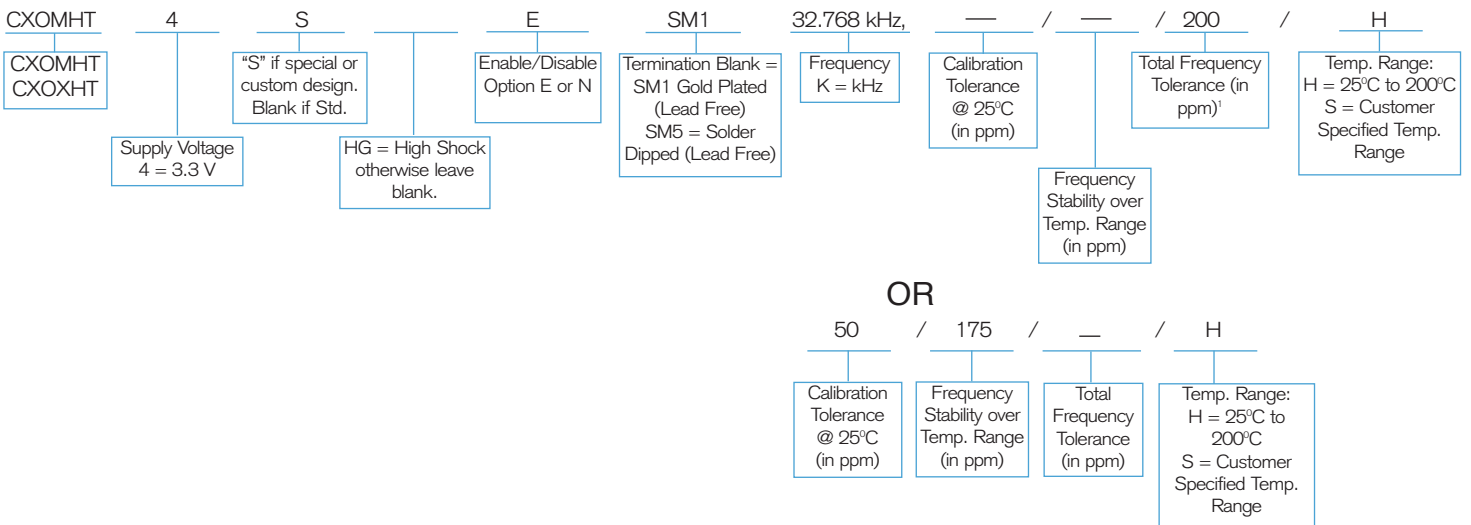

10201 Rev A

